

# Hereditary Geniospasm: Linkage to Chromosome 9q13-q21 and Evidence for Genetic Heterogeneity

P. R. Jarman,<sup>1</sup> N. W. Wood,<sup>1</sup> M. T. Davis,<sup>2</sup> P. V. Davis,<sup>3</sup> K. P. Bhatia,<sup>1</sup> C. D. Marsden,<sup>1</sup> and M. B. Davis<sup>1</sup>

<sup>1</sup>Department of Clinical Neurology, Institute of Neurology, University of London, London; <sup>2</sup>Department of Public Health, North East Hertfordshire Health Authority, United Kingdom; and <sup>3</sup>Department of Family Medicine, University of Alberta, Edmonton

## Summary

Hereditary geniospasm is an unusual movement disorder causing episodes of involuntary tremor of the chin and the lower lip. Episodes typically start in early childhood and may be precipitated by stress, concentration, and emotion. Hereditary geniospasm is inherited as an autosomal dominant trait, and its cause is not known. We report the results of a genomewide genetic linkage study in a four-generation British family with hereditary geniospasm. Positive two-point LOD scores were obtained for 15 microsatellite markers on the peri-centromeric region of chromosome 9. A maximum two-point LOD score of 5.24 at  $\theta = .00$  was obtained for the marker *D9S1837*. Construction of haplotypes defined an interval of 2.1 cM between the flanking markers *D9S1806* and *D9S175*, thus assigning one locus for hereditary geniospasm to the proximal long arm of chromosome 9q13-q21. Hereditary geniospasm in a second British family is not linked to this region, indicating genetic heterogeneity. These findings may have implications for other inherited focal movement disorders that as yet remain unmapped.

## Introduction

Hereditary geniospasm (MIM 190100) is a dominantly inherited movement disorder first described more than 100 years ago. It is characterized by paroxysmal, rhythmic up-and-down movements of the chin and the lower lip, owing to involuntary contractions of the mentalis muscle. Episodes of geniospasm last from seconds to hours and may be triggered by emotion, anxiety, or concentration or may occur without apparent precipitants. The condition typically becomes manifest in infancy or in early life, and episodes tend to reduce in frequency with advancing age. Although the condition

is sometimes distressing and embarrassing, there are no associated abnormalities in most cases, and the condition is considered benign. Geniospasm may occur as a normal phenomenon—for example, as a prelude to crying—but, in the familial form, episodes usually are more prolonged and occur with a variety of precipitants.

The first description of hereditary geniospasm was by Massaro in 1894 (Massaro 1894), who reported a family containing 26 cases over five generations. Several other families subsequently have been reported in the English-language literature (Stocks 1922; Goldsmith 1927; Grossman 1957; Wadlington 1958; Laurance et al. 1968; Johnson et al. 1971; Alsager et al. 1991; Danek 1993; Gordon et al. 1993; Soland et al. 1996). Clinical investigation of individuals suffering from this condition has revealed no consistent associated abnormality, and the cause of hereditary geniospasm is not known.

We have adopted a positional cloning strategy to investigate this unusual movement disorder, in two British families. During the course of a genomewide search for the hereditary-geniospasm locus, we identified linkage to microsatellite markers on the peri-centromeric long arm of chromosome 9, in one family, and defined an ~2.1-cM interval, on chromosome 9q13-q21, containing the hereditary-geniospasm locus. In a second British family, the geniospasm locus has been excluded from this area, indicating genetic heterogeneity.

## Subjects and Methods

### Subjects

We studied two unrelated British families. Family 1 (fig. 1) contained 16 affected individuals (11 still living) over four generations. Family members were interviewed by P.R.J., and venous blood samples were obtained from 20 individuals. Attacks were witnessed in 2 individuals.

Family 2 (fig. 2) contained 20 affected individuals (18 still living) over four generations. Forty-two family members were interviewed by M.B.D., and a detailed history of episodes was obtained. These episodes were witnessed in most individuals. Venous blood samples were obtained from 36 family members and spouses.

Subjects were designated as phenotypically affected or unaffected on the basis of the presence or the absence

Received June 16, 1997; accepted for publication August 5, 1997.

Address for correspondence and reprints: Dr. N. W. Wood, Department of Clinical Neurology, Institute of Neurology, Queen Square, London WC1N 3BG, United Kingdom. E-mail: pjarman@hgmprc.ac.uk

© 1997 by The American Society of Human Genetics. All rights reserved.  
0002-9297/97/6104-0022\$02.00

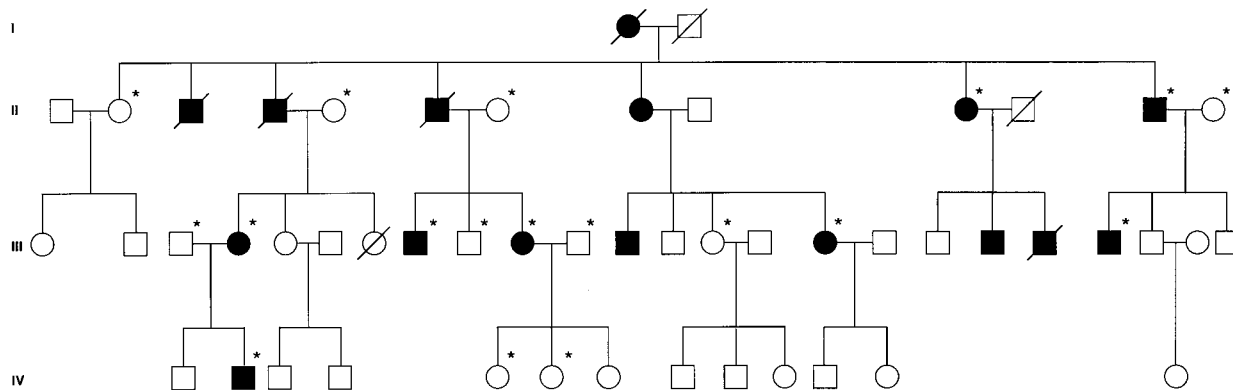

**Figure 1** Pedigree of family 1, modified and updated from Soland et al. (1996). Affected status is denoted by blackened symbols. An asterisk (\*) indicates individuals for whom DNA was available for study.

of a history of typical attacks. Informed consent was obtained from all subjects.

*DNA Analysis*

DNA was extracted from peripheral blood leukocytes by use of standard techniques. Microsatellite markers were amplified from genomic DNA by use of PCR, as described elsewhere (Reed et al. 1994). PCR reactions were performed in a 96-well microtitre plate, in a reaction volume of 20 µl, with 50 ng of DNA. PCR primers

were fluorescently tagged. PCR products were analyzed by electrophoresis on a 4% acrylamide gel, by use of an automatic DNA fragment sequencer (Prism 377; Applied Biosystems) and Genescan software. Genotypes were assigned by use of the Genotyper program (version 1.0) (Applied Biosystems).

*Linkage Analysis*

A genomewide linkage search for the geniospasm locus was undertaken for family 2 by use of the panel of

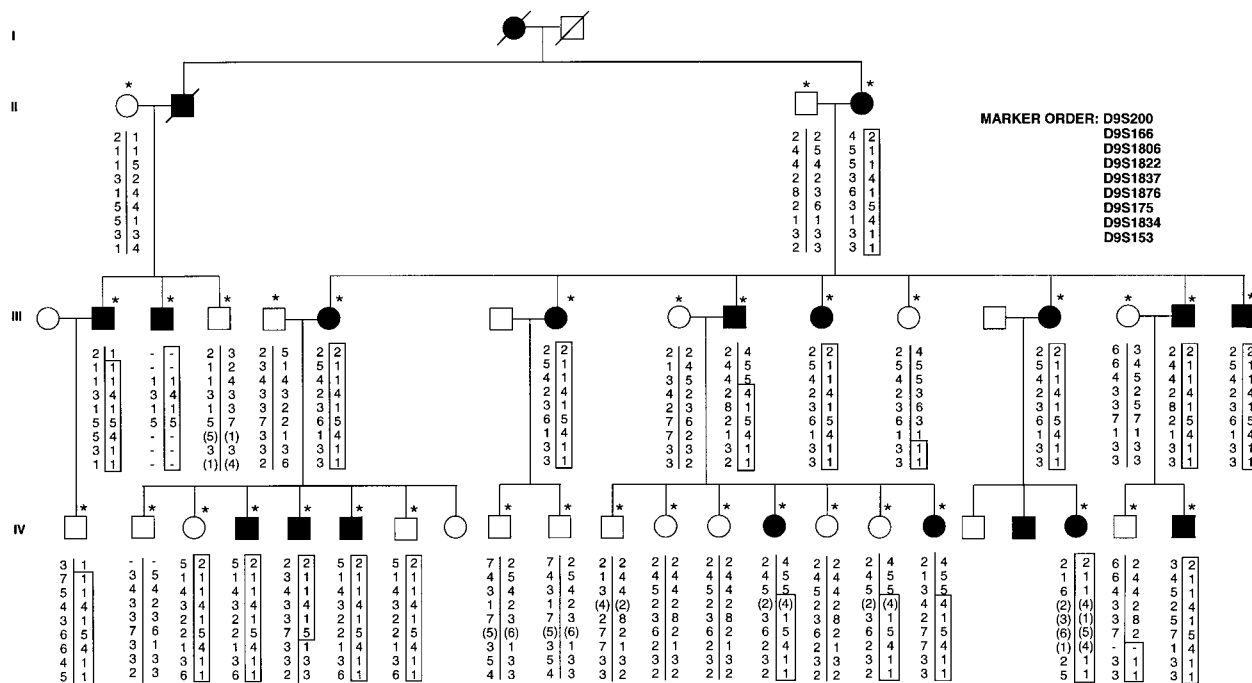

**Figure 2** Pedigree of hereditary-geniospasm family 2, updated and corrected from Soland et al. (1996). Affected status is denoted by blackened symbols. An asterisk (\*) indicates individuals for whom DNA was available for analysis. Haplotypes for chromosome 9 markers are shown, with boxes surrounding haplotypes cosegregating with the trait. Alleles in parentheses are those for which phase could not be determined with certainty. Dashes are used when the marker could not be typed. Informative recombination events occurred in individuals III-10 and IV-5, placing the disease locus between the markers D9S1806 and D9S175, in this family. Four asymptomatic individuals (IV-1, IV-3, IV-7, and IV-16) have inherited the associated haplotype in whole or in part.

markers from the United Kingdom Medical Research Council Human Genome Mapping Project primer set (Reed et al. 1994). Areas in family 2 that yielded positive LOD scores were studied subsequently for evidence of linkage in family 1. One hundred ten microsatellite markers, distributed over 16 chromosomes, were analyzed in family 2. The 15 microsatellite markers from the peri-centromeric region of chromosome 9 were mostly from the Génethon map (Dib et al. 1996). Pairwise LOD scores between the disease locus and *D9S147E* (9pter-qter), *D9S161* (9p21), *D9S43* (9p21), *D9S1791* (9pter-qter), *D9S200* (9p12-p21), *D9S166* (9p21-q21), *D9S1806* (9pter-qter), *D9S1822* (9pter-qter), *D9S276* (9q13-q22), *D9S1837* (9pter-qter), *D9S1876* (9pter-qter), *D9S175* (9q13-q21), *D9S1834* (9pter-qter), *D9S153* (9q13-q22), and *D9S257* (9q13-q22) were generated by use of the FASTLINK program (version 3.0P) of MLINK (Lathrop et al. 1984; Cottingham et al. 1993). Marker allele frequencies were assumed to be equal. An autosomal dominant model of inheritance was used, with a disease penetrance of 80% and a disease allele frequency of .0001.

#### Haplotype Analysis

Haplotypes were assigned manually.

## Results

### Subjects

The clinical characteristics of the families studied have been reported previously by Soland et al. (1996). Affected individuals experience characteristic involuntary up-and-down movement of the tip of the chin, with a superimposed quivering activity and movement of the lower lip. Episodes of geniospasm frequently are precipitated by stress, concentration, or extremes of emotion or occur spontaneously, particularly in young children, and usually last several minutes. In all cases in this study, the onset of symptoms is in infancy or in early childhood, and, in one family member, geniospasm was observed as early as hours after birth. All adults report a marked tendency for attacks to become less frequent as they became older, the highest frequency occurring during childhood and adolescence. Affected individuals are entirely normal between attacks. Some affected individuals in family 2 suffered from nocturnal involuntary tongue biting during early childhood. There were no other associated neurological abnormalities. The phenotypic appearance of geniospasm is the same in both families, and, in most respects, the clinical findings are typical of other families with hereditary geniospasm, as described in the English-language literature (Stocks 1922; Goldsmith 1927; Grossman 1957; Wadlington 1958; Laurance et al. 1968; Johnson et al. 1971; Alsager et al. 1991; Danek 1993; Gordon et al. 1993; Soland et al. 1996).

### Linkage Analysis (Family 2)

One hundred ten polymorphic microsatellite markers, on 16 chromosomes, were analyzed before linkage to the marker *D9S175* was obtained for family 2 ( $Z_{\max} = 2.5$  at  $\theta = .10$ ); there was no evidence to support linkage of the hereditary-geniospasm locus to any of the other markers screened. After initial linkage to *D9S175* was determined, this region was examined in detail by use of 15 closely spaced microsatellite markers surrounding *D9S175*. The Galton chromosome 9 map (Povey et al. 1997) places these markers in the following order: pter-*D9S147E*-interlocus distance not determined accurately (Reed et al. 1994)-*D9S161*-3.8 cM-*D9S43*-3.4 cM-*D9S1791*-5.8 cM-*D9S200*-4.1 cM-*D9S166*-0.5 cM-*D9S1806*-0.2 cM-*D9S1822*-*D9S1822*-0.4 cM-*D9S276*-0.0 cM-*D9S1837*-0.2 cM-*D9S1876*-1.3 cM-*D9S175*-4.0 cM-*D9S1834*-5.8 cM-*D9S153*-15.5 cM-*D9S257*-qter (fig. 3). Distances between markers were sex averaged.

For family 2, pairwise LOD scores between microsatellite markers and the hereditary-geniospasm locus are given in table 1 (for 80% penetrance). Maximum LOD scores were obtained with the following markers: *D9S1822* ( $Z_{\max} = 4.7$  at  $\theta = .00$ ), *D9S1837* ( $Z_{\max} = 5.24$  at  $\theta = .00$ ), and *D9S1876* ( $Z_{\max} = 4.91$  at  $\theta$

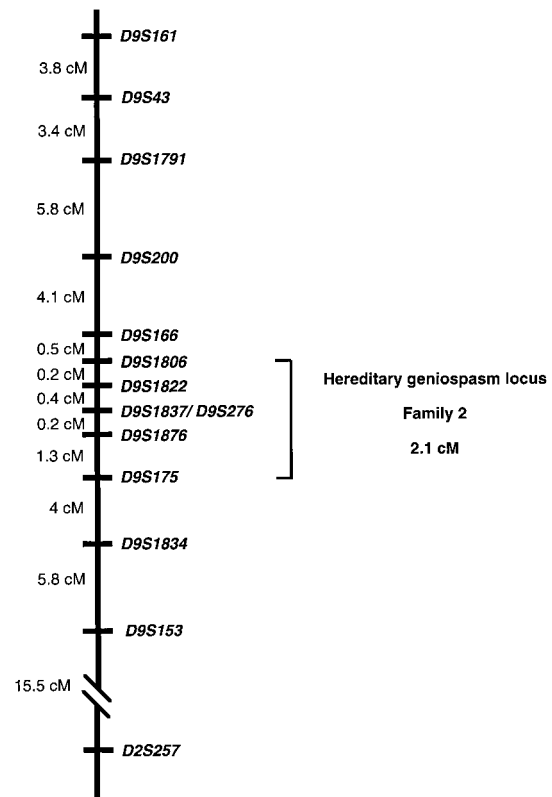

**Figure 3** Schematic representation of the genetic map of the peri-centromeric part of chromosome 9, showing the hereditary-geniospasm candidate interval flanked by the markers *D9S1806* and *D9S175*. Sex-averaged genetic distances are given in centimorgans.

**Table 1****Two-Point LOD Scores between the Hereditary-Geniospasm Locus in Family 2 and Microsatellite Markers on Chromosome 9**

| MARKER  | LOD SCORE AT $\theta =$ |       |       |      |      |      |      |      |
|---------|-------------------------|-------|-------|------|------|------|------|------|
|         | .00                     | .001  | .01   | .05  | .10  | .20  | .30  | .40  |
| D9S147E | $-\infty$               | -1.22 | -.20  | .54  | .83  | .94  | .74  | .35  |
| D9S161  | .10                     | .10   | .15   | .30  | .42  | .49  | .43  | .26  |
| D9S43   | $-\infty$               | .42   | 1.41  | 2.04 | 2.18 | 1.99 | 1.46 | .72  |
| D9S1791 | $-\infty$               | .47   | 1.47  | 2.10 | 2.25 | 2.05 | 1.52 | .77  |
| D9S200  | -8.02                   | .90   | 1.85  | 2.31 | 2.31 | 1.92 | 1.32 | .60  |
| D9S166  | $-\infty$               | 1.43  | 2.40  | 2.94 | 2.99 | 2.60 | 1.88 | .94  |
| D9S1806 | -15.28                  | 1.77  | 2.74  | 3.26 | 3.28 | 2.83 | 2.05 | 1.02 |
| D9S1822 | 4.70                    | 4.69  | 4.65  | 4.43 | 4.10 | 3.30 | 2.30 | 1.12 |
| D9S1837 | 5.24                    | 5.23  | 5.18  | 4.93 | 4.55 | 3.64 | 2.54 | 1.24 |
| D9S1876 | 4.91                    | 4.91  | 4.86  | 4.61 | 4.25 | 3.39 | 2.35 | 1.14 |
| D9S175  | -2.86                   | .83   | 1.81  | 2.40 | 2.50 | 2.22 | 1.62 | .80  |
| D9S1834 | -3.28                   | -.41  | .62   | 1.37 | 1.66 | 1.67 | 1.31 | .66  |
| D9S153  | -4.31                   | -.61  | .42   | 1.17 | 1.46 | 1.51 | 1.19 | .61  |
| D9S257  | $-\infty$               | -5.61 | -2.62 | -.51 | .32  | .88  | .83  | .44  |

= .00). *D9S276* was not included, since it was relatively uninformative in this family. LOD scores also were calculated with the penetrance of geniospasm set at 100%, to provide a more conservative means for the assessment of linkage. By use of this model, the maximum LOD scores remained significant for linkage of the geniospasm locus to the following markers: *D9S1822* ( $Z_{\max} = 3.6$  at  $\theta = .10$ ), *D9S1837* ( $Z_{\max} = 4.12$  at  $\theta = .10$ ), and *D9S1876* ( $Z_{\max} = 3.77$  at  $\theta = .10$ ). These data allowed the locus for hereditary geniospasm to be assigned to the proximal long arm of chromosome 9 at 9q13-q21, in this family.

#### Haplotype Analysis (Family 2)

Haplotypes for nine chromosome 9 markers are shown in figure 2. Construction of haplotypes allowed definition of a candidate interval of 2.1 cM between the flanking markers *D9S1806* and *D9S175*. Recombinations in individuals III-10 and IV-5 placed the locus distal to *D9S1806* and proximal to *D9S175*, respectively. No recombinations were observed between the disease locus and the markers *D9S1822*, *D9S1837*, *D9S276*, and *D9S1876*. Four family members (IV-1, IV-3, IV-7, and IV-16) had inherited the associated haplotype as a whole or in part but were unaffected. All four asymptomatic gene carriers were >13 years of age and, therefore, would be expected to have developed symptoms by this age, given the early onset of geniospasm in most cases.

#### Linkage Analysis (Family 1)

The linked markers spanning the critical region on chromosome 9 were analyzed for family 1. Pairwise LOD scores for family 1 are given in table 2. All markers

yielded negative LOD scores at  $\theta = .00-.10$ , thus excluding the geniospasm locus from this interval, in family 1.

#### Discussion

Our data clearly establish the existence of a locus for autosomal dominant hereditary geniospasm, on the proximal long arm of chromosome 9, in a large British kindred. We have assigned the locus to a relatively small candidate region of 2.1 cM, between the flanking markers *D9S1806* and *D9S175* in the cytogenetic region 9q13-q21. Furthermore, genetic heterogeneity has been demonstrated in a second unrelated British family.

Geniospasm is considered benign, but it can lead to considerable embarrassment and distress in some affected individuals and may result in significant psychosocial morbidity (Gordon et al. 1993; Soland et al. 1996). Severe tongue lacerations may occur as a result of nocturnal tongue biting (five individuals in family 1, and in the family described by Johnson et al. [1971]). Hereditary geniospasm may present to neurologists or to pediatricians, but most affected family members do not seek medical attention; therefore, it seems likely that the true prevalence of the condition is higher than is suggested by the relatively small number of reported families.

Some authors have suggested that hereditary geniospasm exhibits almost complete penetrance (Goldsmith 1927; Gordon et al. 1993; Soland et al. 1996). However, our finding of four asymptomatic gene carriers in one family suggests that penetrance is lower than that suggested elsewhere. Indeed, there are several instances of unaffected obligate gene carriers, in families reported in

**Table 2**

**Two-Point LOD Scores between the Hereditary-Geniospasm Locus in Family 1 and Microsatellite Markers Spanning the Chromosome 9 Candidate Interval**

| MARKER  | LOD SCORE AT $\theta =$ |       |       |       |       |      |      |      |
|---------|-------------------------|-------|-------|-------|-------|------|------|------|
|         | .00                     | .001  | .01   | .05   | .10   | .20  | .30  | .40  |
| D9S166  | $-\infty$               | -8.05 | -5.01 | -2.75 | -1.71 | -.70 | -.22 | -.01 |
| D9S1806 | $-\infty$               | -7.18 | -4.16 | -2.03 | -1.13 | -.35 | -.03 | .06  |
| D9S1822 | -16.59                  | -7.31 | -4.29 | -2.15 | -1.23 | -.41 | -.07 | .05  |
| D9S276  | -11.27                  | -3.94 | -1.96 | -.68  | -.22  | .11  | .20  | .15  |
| D9S1837 | -11.12                  | -7.62 | -4.59 | -2.24 | -1.25 | -.40 | -.05 | .05  |
| D9S1876 | -16.53                  | -6.91 | -3.91 | -1.85 | -1.00 | -.29 | -.01 | .06  |
| D9S175  | $-\infty$               | -6.45 | -3.47 | -1.44 | -.64  | -.03 | .15  | .14  |

previous studies (Stocks 1922; Ganner and Vonbun 1935; Becker 1982; Alsager et al. 1991; Gordon et al. 1993). Therefore, the penetrance figure of 80%, used in this study, may be closer to the true value.

It has been suggested that hereditary geniospasm may be a *forme fruste* of other inherited dyskinesias, such as focal dystonia or essential tremor, with which it is sometimes classified (Danek 1993). Essential tremor has been claimed to affect the jaw or the tongue (Biary and Koller 1987; Rapoport et al. 1991; Bain et al. 1994), and focal tremor can occur with dystonia (Jedynak et al. 1991). One of the major genetic loci for generalized childhood-onset dystonia, DYT1, maps to chromosome 9q34 (Ozelius et al. 1989; Kramer et al. 1994) and, therefore, is genetically distinct from hereditary geniospasm. Focal dystonia has been assigned to a locus on the short arm of chromosome 18, in one kindred with adult-onset torticollis (Leube et al. 1996), indicating that geniospasm in family 2 in this study and focal dystonia in the kindred described by Leube et al. (1996) are genetically distinct. However, in most families, the loci for essential tremor and focal dystonia remain unmapped. Paroxysmal dystonic choreoathetosis (PDC), a disorder causing episodic dystonia and chorea, with no abnormality between attacks, has been mapped to loci on chromosomes 2q (Fink et al. 1996; Fouad et al. 1996; Jarman et al., in press) and 1p (Auburger et al. 1996) in a number of families. However, the clinical differences between PDC and hereditary geniospasm and the genetic mapping data indicate that the two conditions are not allelic. Linkage of the hereditary-geniospasm locus to chromosome 9q may facilitate the elucidation of other inherited movement disorders.

Our finding that a second, unrelated British family with geniospasm is not linked to markers on the proximal long arm of chromosome 9 demonstrates that hereditary geniospasm is genetically heterogeneous and indicates the existence of at least one other locus capable of producing an almost identical phenotype. Further linkage studies to identify the second geniospasm locus will therefore be required.

The cause of hereditary geniospasm is not known. The mentalis muscle fibers are innervated by the ipsilateral facial nerve nucleus in the brain stem (Welt and Abbs 1990). The bilateral nature of the movement, affecting most of the mentalis muscle, suggests that the abnormality may lie either within the muscle itself or at the level of higher cortical or midbrain centers. Other paroxysmal disorders, such as episodic ataxia and periodic paralysis, are caused by abnormalities of voltage-gated ion channels (Ptacek et al. 1991, 1994; Browne et al. 1994), and such abnormalities may be a possible mechanism for the generation of the involuntary muscle contractions of this condition. Such genes would be suitable candidates for further investigation. However, no ion-channel genes are known to map to the candidate region, and none of the genes currently mapped to 9q13-q21 are good candidates for the geniospasm gene. The tight genetic linkage of the hereditary-geniospasm locus to a 2.1-cM interval in family 2 makes the physical mapping of the responsible gene a realistic possibility. Understanding of the genetic basis of this condition would be of biological interest and would lead to an advance in our understanding of other movement disorders.

## Acknowledgments

We are very grateful to all the family members, for their participation in this study; to Dr. Dave Dawson, for his assistance with the collection of blood samples; to Prof. Sue Povey, for her helpful discussion; and to Lee Williams, for technical assistance. P.R.J. is supported by a Wellcome Research Training Fellowship.

## References

- Alsager DE, Bowen P, Bamforth JS (1991) Trembling chin: a report of this inheritable dominant character in a four-generation Canadian family. *Clin Genet* 40:186-189
- Auburger G, Ratzlaff T, Lunke A, Nelles HW, Leube B, Binkofski F, Kugel H, et al (1996) A gene for autosomal domi-

- nant paroxysmal choreoathetosis/spasticity (CSE) maps to the vicinity of a potassium channel gene cluster on chromosome 1p, probably within 2 cM between D1S443 and D1S197. *Genomics* 31:90–94
- Bain PG, Findley LJ, Thompson PD, Gresty MA, Rothwell JC, Harding AE, Marsden CD (1994) A study of hereditary essential tremor. *Brain* 117:805–824
- Becker H (1982) Erbliches Kinnzittern in einer westspanischen Familie. *Arch Psychiatr Nervenkr* 231:509–518
- Biary N, Koller WC (1987) Essential tongue tremor. *Mov Disord* 2:25–29
- Browne DL, Ganchar ST, Nutt JG, Brunt ER, Smith EA, Kramer P, Litt M (1994) Episodic ataxia/myokymia syndrome is associated with point mutations in the human potassium channel gene, KCNA1. *Nat Genet* 8:136–140
- Cottingham RW Jr, Indury RM, Schäffer AA (1993) Faster sequential genetic linkage computations. *Am J Hum Genet* 53:252–263
- Danek A (1993) Geniospasm: hereditary chin trembling. *Mov Disord* 8:335–338
- Dib C, Fauré S, Fizames C, Samson D, Drouot N, Vignal A, Millasseau P, et al (1996) A comprehensive genetic map of the human genome based on 5,264 microsatellites. *Nature* 380:152–154
- Fink JK, Rainier S, Wilkowski J, Jones SM, Kume A, Hedera P, Albin R, et al (1996) Paroxysmal dystonic choreoathetosis: tight linkage to chromosome 2q. *Am J Hum Genet* 59:140–145
- Fouad GT, Servidei S, Durcan S, Bertini E, Ptáček LJ (1996) A gene for familial paroxysmal dyskinesia (FPD1) maps to chromosome 2q. *Am J Hum Genet* 59:135–139
- Ganner H, Vonbun A (1935) Erbliches Kinnzittern in einer Tiroler Talschaft. *Arch Rassenbiol* 29:121–132
- Goldsmith JB (1927) The inheritance of “facial spasm.” *J Hered* 18:185–187
- Gordon K, Cadera W, Hinton G (1993) Successful treatment of hereditary trembling chin with botulinum toxin. *J Child Neurol* 8:154–156
- Grossman BJ (1957) Trembling of the chin: an inheritable dominant character. *Pediatrics* 19:453–455
- Jarman PR, Davis MB, Hodgson SV, Marsden CD, Wood NW. Paroxysmal dystonic choreoathetosis: genetic linkage studies in a British family. *Brain* (in press)
- Jedynak CP, Bonnet AM, Agid Y (1991) Tremor and idiopathic dystonia. *Mov Disord* 6:230–236
- Johnson LF, Kinsbourne M, Renuart AW (1971) Hereditary chin-trembling with nocturnal myoclonus and tongue-biting in dizygous twins. *Dev Med Child Neurol* 13:726–729
- Kramer PL, Heiman GA, Gasser T, Ozelius LJ, de Leon D, Brin MF, Burke RE, et al (1994) The DYT1 gene on 9q34 is responsible for most cases of early limb-onset idiopathic torsion dystonia in non-Jews. *Am J Hum Genet* 55:468–475
- Lathrop GM, Laouel JM (1984) Easy calculations of LOD scores and genetic risks on small computers. *Am J Hum Genet* 36:460–465
- Laurance BM, Matthews WB, Diggle JH (1968) Hereditary quivering of the chin. *Arch Dis Child* 43:249–251
- Leube B, Rudnicki D, Ratzlaff T, Kessler KR, Benecke R, Auburger G (1996) Idiopathic torsion dystonia: assignment of a gene to chromosome 18p in a German family with adult onset, autosomal dominant inheritance and purely focal distribution. *Hum Mol Genet* 5:1673–1677
- Massaro D (1894) Ventisei casi de geniospasmio attraverso cinque generazioni: contributo clinico allo studio dell’eredità fisio-patologica. *I Pisani* (Palermo) 1:47–56
- Ozelius L, Kramer PL, Moskowitz CB, Kwiatkowski DJ, Brin M, Bressman SB, Brin MF, et al (1989) Human gene for torsion dystonia located on chromosome 9q32-q34. *Neuron* 2:1427–1434
- Povey S, Attwood J, Chadwick B, Frezal J, Haines JL, Knowles M, Kwiatkowski DJ, et al (1997) Report on the Fifth International Workshop on Chromosome 9. *Ann Hum Genet* 61:183–206
- Ptacek LJ, George AL Jr, Griggs RC, Tawil R, Kallen RG, Barchi RL, Robertson M, et al (1991) Identification of a mutation in the gene causing hyperkalemic periodic paralysis. *Cell* 67:1021–1027
- Ptacek LJ, Tawil R, Griggs RC, Engel AG, Layzer RB, Kwiecinski H, McManis PG, et al (1994) Dihydropyridine receptor mutations cause hypokalemic periodic paralysis. *Cell* 77:863–868
- Rapoport A, Lampel Y, Sarova I (1991) Clinical and epidemiological features of essential tremor of the jaw. *Mov Disord* 6:276
- Reed PW, Davies JL, Copeman JB, Bennett ST, Palmer SM, Pritchard LE, Gough SC, et al (1994) Chromosome-specific microsatellite sets for fluorescence-based, semi-automated genome mapping. *Nat Genet* 7:390–395
- Soland VL, Bhatia KP, Sheehan GL, Marsden CD (1996) Hereditary geniospasm: two new families. *Mov Disord* 11:744–761
- Stocks P (1922) Facial spasm inherited through four generations. *Biometrika* 14:311–315
- Wadlington WB (1958) Familial trembling of the chin. *J Pediatr* 53:316–321
- Welt C, Abbs JH (1990) Musculotopic organization of the facial motor nucleus in *Macaca fascicularis*: a morphometric and retrograde tracing study with cholera toxin B-HRP. *J Comp Neurol* 291:621–636